

Crazee-BA7

Designed by: Stan Yeo
 Span: 1200mm Engines: 20-32 cu.in
 Type: EPP Sport Aerobatic Power

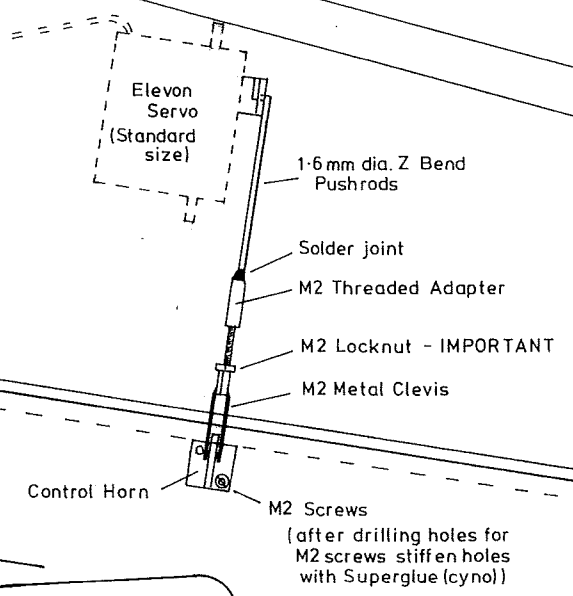

CONTROL MOVEMENTS
 Ailerons ± 13mm
 Elevator ± 11mm

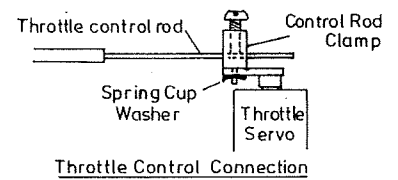
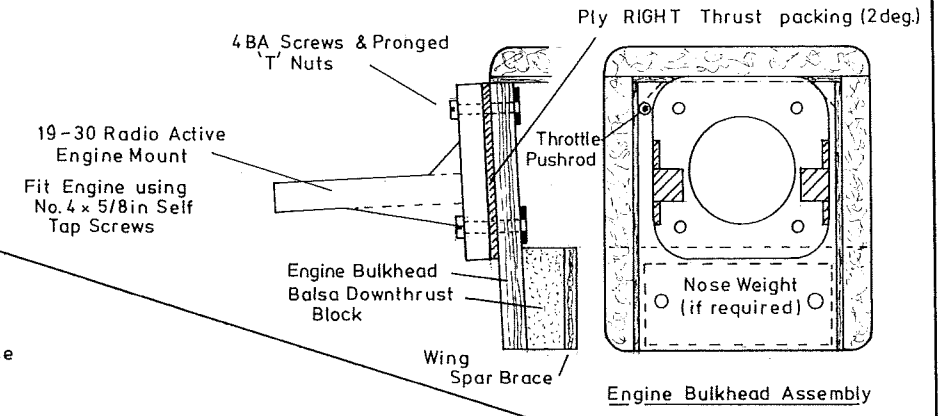
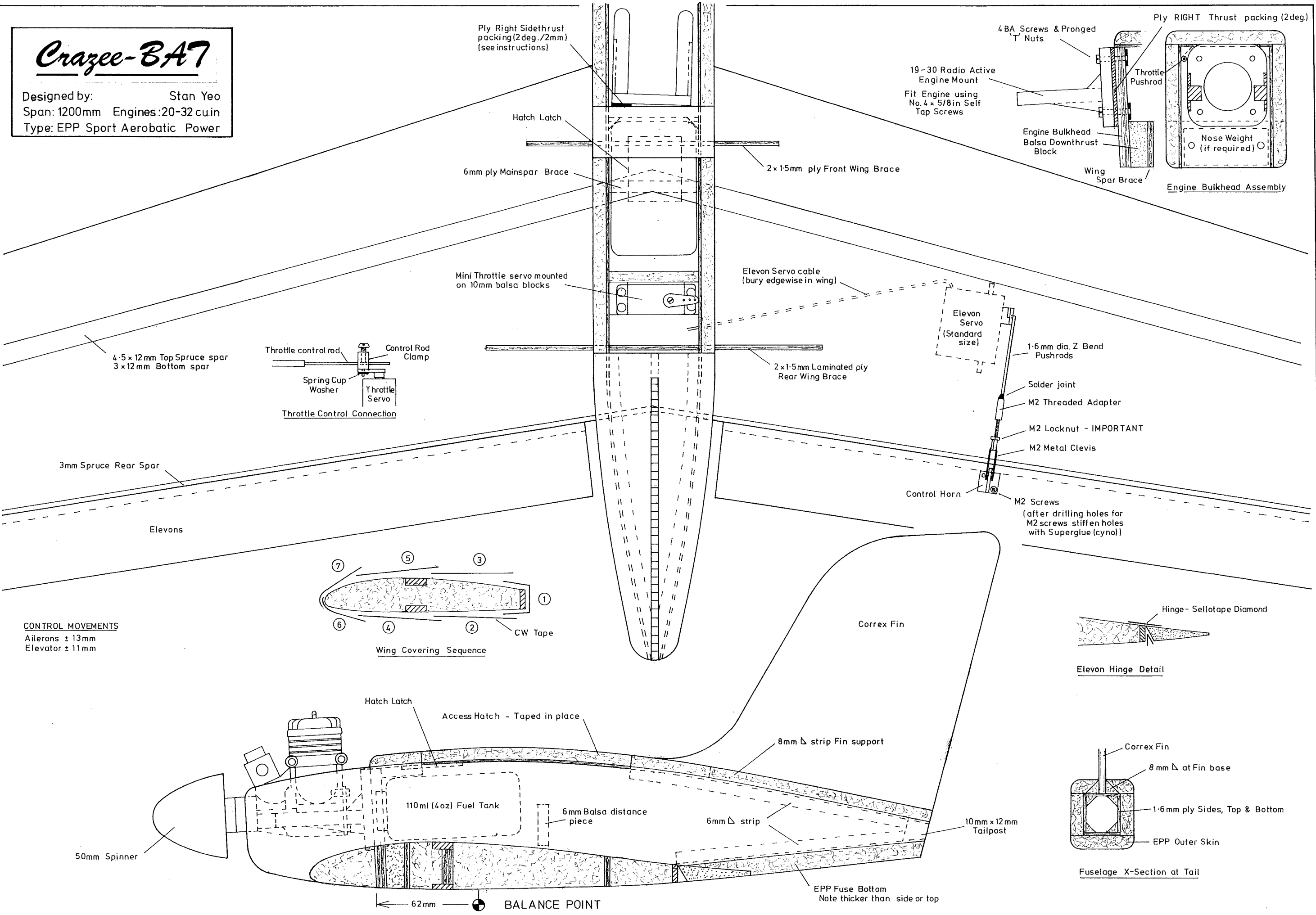